

Für diese Zeichnung behalten wir uns alle Rechte vor. Ohne unsere vorherige Zustimmung darf diese Unterlage nicht vervielfältigt oder Dritten zugänglich gemacht werden.
PAN-METALLGESELLSCHAFT
 Baumgärtner GmbH & Co KG

with Hexagon socket pipe plugs DIN 906 - Ms - M12 x 1,5 closed.

with Hexagon socket pipe plugs DIN 906 - Ms - M12 x 1,5 closed.

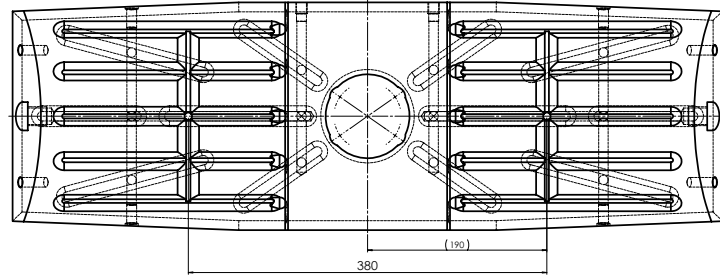
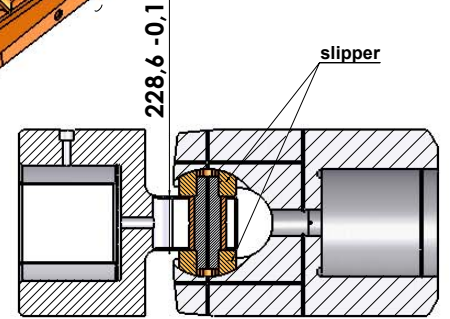
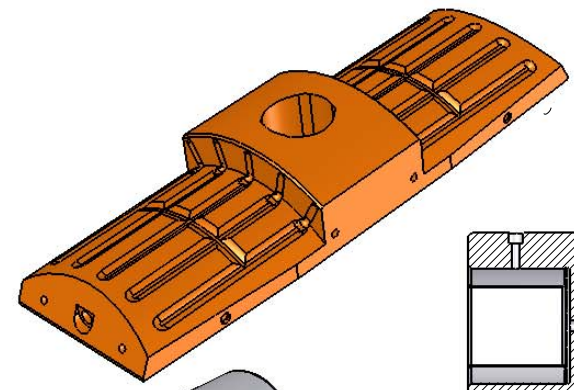
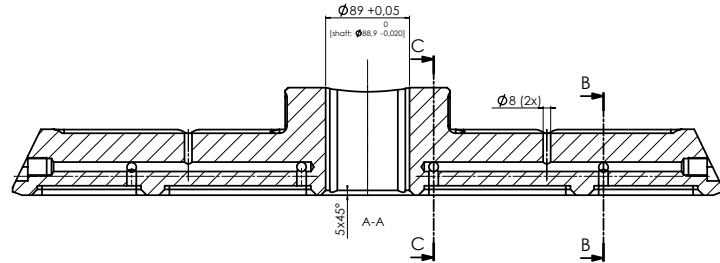

3.2 / (0.8)

Zeichn.:	02.07.03	Name:	slipper	PAN-Metallgesellschaft Mannheim
Skizze:		Größe:		
Vergrößerung:	1:2	25.1.62.4554 PAN-SoMs 210		25.1.62.4554 20

m = 87,6 kg